

Please check the examination details below before entering your candidate information

Candidate surname					Other names				
Centre Number				Candidate Number					
<input type="text"/>	<input type="text"/>	<input type="text"/>	<input type="text"/>	<input type="text"/>	<input type="text"/>	<input type="text"/>	<input type="text"/>	<input type="text"/>	<input type="text"/>

Pearson Edexcel International GCSE (9–1)

Time 2 hours

Paper reference **4CP0/01**

Computer Science

PAPER 1: Principles of Computer Science

You must have:
Pseudocode command set (enclosed)

Total Marks

Instructions

- Use **black** ink or ball-point pen.
- **Fill in the boxes** at the top of this page with your name, centre number and candidate number.
- Answer **all** questions.
- Answer the questions in the spaces provided
– *there may be more space than you need.*

Information

- The total mark for this paper is 80.
- The marks for **each** question are shown in brackets
– *use this as a guide as to how much time to spend on each question.*
- You are not allowed to use a calculator.

Advice

- Read each question carefully before you start to answer it.
- Try to answer every question.
- Check your answers if you have time at the end.
- Marks will not be awarded for using product or trade names in answers without giving further explanation.

Turn over ►

P69297A

©2021 Pearson Education Ltd.

E:1/1/1/



Pearson

Answer ALL questions. Write your answers in the spaces provided.

Some questions must be answered with a cross in a box ☒. If you change your mind about an answer, put a line through the box ☒ and then mark your new answer with a cross ☒.

1 Computers use binary to represent and store data.

(a) Binary and hexadecimal notation can be used to represent numbers.

(i) Convert the denary number 77 to 8-bit binary.

(2)

(ii) Convert the denary number -126 to 8-bit binary using two's complement.

(2)

(iii) Convert the binary pattern 11000110 to hexadecimal.

(2)

DO NOT WRITE IN THIS AREA

DO NOT WRITE IN THIS AREA

DO NOT WRITE IN THIS AREA



(b) Images are stored as binary data.

(i) A bitmap image is 400 pixels wide by 200 pixels high.

It has a colour depth of 12 bits.

Construct an expression to show how the image size, in bytes, is calculated.

Do **not** calculate the answer.

(2)

(ii) **Figure 1** is an image of an icon, set out in an 8×8 pixel grid.

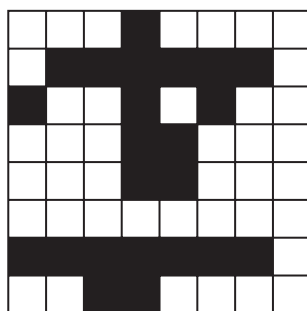

Figure 1

A run-length encoding compression algorithm uses:

- W for white pixels
- B for black pixels.

Give the result of compressing the first 4 lines of the icon using the algorithm.

(3)

Line 1

Line 2

Line 3

Line 4



(iii) Run-length encoding is a type of lossless compression.

State what is meant by the term **lossless** in this context.

(1)

DO NOT WRITE IN THIS AREA

DO NOT WRITE IN THIS AREA

DO NOT WRITE IN THIS AREA

(c) Raoul wants to record a song and store it as a digital sound file.

Figure 2 shows an overview of the process of recording a song and storing it as a digital sound file.

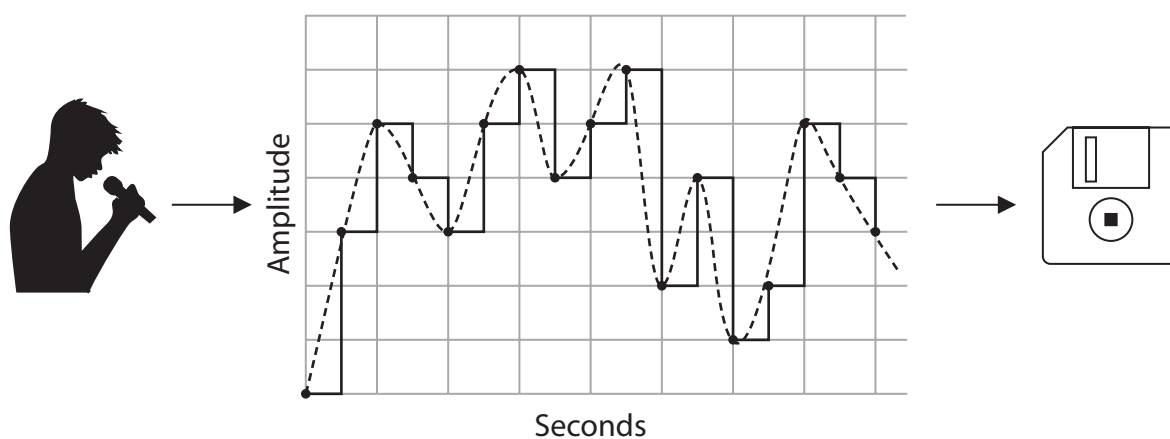

Figure 2

(i) Describe the steps taken to convert the analogue sound to a digital sound file.

(3)



(ii) Raoul uses a lossy algorithm to compress the file.

Give **one** reason why the sound quality of the compressed file may not be as good as the uncompressed version.

(1)

(Total for Question 1 = 16 marks)

DO NOT WRITE IN THIS AREA

DO NOT WRITE IN THIS AREA

DO NOT WRITE IN THIS AREA



2 Danielle manages network security for a small business.

(a) Identify **one** action Danielle could take to protect the **network** from unauthorised access.

(1)

- A** Give each user a separate account
- B** Enforce a strong password policy
- C** Make a backup plan
- D** Encrypt sensitive files

(b) Danielle has received this email.

She is a customer of SafePayment.com but thinks this is a phishing attempt.

From: SafePayment.accounts@5safepayment.com
To: Danielle616
Subject: Account restricted (case SP-0011312-2021-06)

Dear Customer,

We have noticed some unusual activity on your account, so have stopped all payments.

Please use this link to log in and check your account.

Log in

Your normal log in will stop working until you have done this.

Regards
 SafePayment fraud prevention team.

(i) Danielle has circled the words **Dear Customer**.

Give **one** reason why the use of these words might make Danielle suspect that the email is a phishing attempt.

(1)

(ii) Draw circles around **two other** aspects of the email that might make Danielle suspect it is a phishing attempt.

(2)



(c) Some employees use company laptops in public places.

Danielle is concerned that shoulder surfing could pose a risk to security.

(i) Describe what is meant by **shoulder surfing**.

(2)

(ii) Explain **one** way to prevent shoulder surfing.

(2)

(d) Danielle wants to protect the network from cyberattacks.

(i) Identify the purpose of penetration testing.

(1)

- A To decompile executable code
- B To identify security vulnerabilities
- C To test the strength of an encryption algorithm
- D To enforce a network user policy



(ii) Danielle is sent a software patch for the network operating system but is too busy to install it straight away.

Explain why this delay could pose a threat to the security of the network.

(2)

.....

.....

.....

.....

(Total for Question 2 = 11 marks)

DO NOT WRITE IN THIS AREA

DO NOT WRITE IN THIS AREA

DO NOT WRITE IN THIS AREA



3 Carlo uses his smartphone to make hands-free calls from the car.

(a) The smartphone connects to the car wirelessly forming a network.

Complete the table by adding a tick (✓) to indicate the network type and a tick (✓) to indicate the usage model the network uses.

(2)

Network type	Tick (✓)	Usage model	Tick (✓)
Local Area Network (LAN)		Client-Server	
Wide Area Network (WAN)		Peer-to-peer	
Personal Area Network (PAN)			

(b) Data on a network is transmitted between devices using packets and the TCP/IP layered protocol stack.

Complete the table by naming **two** layers of the stack and giving **one** function for each of the layers that you have named.

(4)

	Layer name	Function
1		
2		

DO NOT WRITE IN THIS AREA

DO NOT WRITE IN THIS AREA

DO NOT WRITE IN THIS AREA



P 6 9 2 9 7 A 0 9 2 0

(c) The smartphone can communicate using Wi-Fi.

Identify which **one** of these is a radio frequency used by smartphones to connect to Wi-Fi.

(1)

- A** 2.4 GHz
- B** 3 KHz
- C** 4.1 GHz
- D** 5 KHz

(d) Carlo's smartphone can use 3G, 4G and 5G mobile communication standards.

(i) Give **one** advantage of using a higher frequency band for mobile communications.

(1)

(ii) Explain **one** benefit to Carlo of using 5G rather than 3G.

(2)

(e) Carlo wants to reduce the environmental impact of his smartphone.

(i) Give **one** way Carlo could reduce energy consumption.

(1)

(ii) Explain **one** way, other than reducing energy consumption, that Carlo could reduce the environmental impact of his smartphone.

(2)

(Total for Question 3 = 13 marks)



DO NOT WRITE IN THIS AREA

DO NOT WRITE IN THIS AREA

DO NOT WRITE IN THIS AREA

BLANK PAGE



4 Algorithms can be used to perform calculations and to process data.

(a) State what is meant by the term **algorithm**.

(1)

(b) **Figure 3** shows an algorithm.

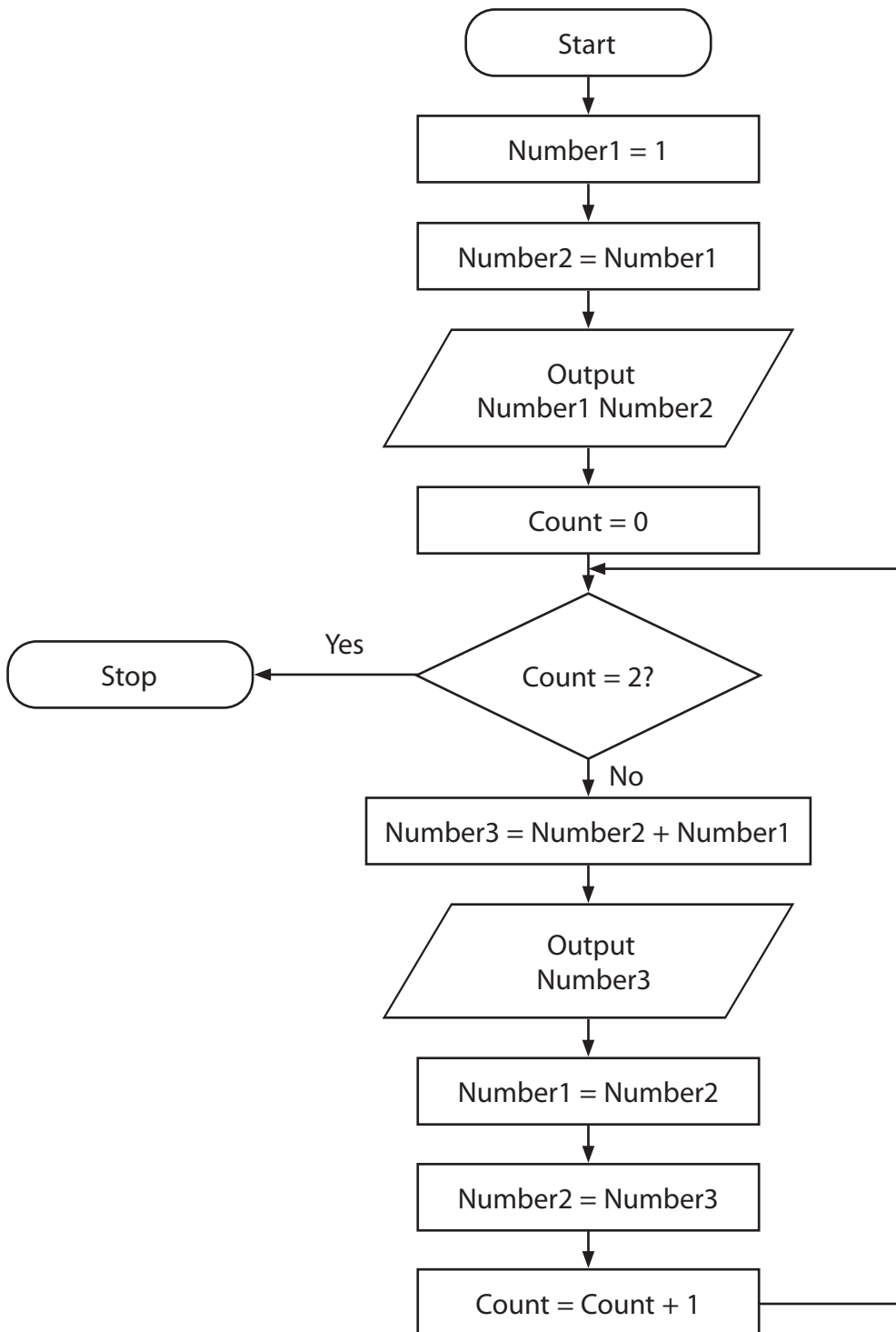

Figure 3

DO NOT WRITE IN THIS AREA

DO NOT WRITE IN THIS AREA

DO NOT WRITE IN THIS AREA



(i) Complete this trace table for the algorithm.

You may not need to use all the rows.

(5)

Number1	Number2	Number3	Count	Output	Count = 2?
1	1	–	0	1 1	False

(ii) The benefits of using a trace table include that they allow variable states, outputs and decisions to be recorded.

Give **one other** benefit of using a trace table to test an algorithm.

(1)

.....

.....



P 6 9 2 9 7 A 0 1 3 2 0

(c) An algorithm is needed to count and display the number of vowels in a word.

The vowels are a, e, i, o, and u.

The completed algorithm must:

- count the number of vowels
- create a message as a single string (e.g. there are *number* vowels)
- print the message to the display.

Here is a partially completed algorithm written in pseudocode.

Complete the algorithm in the spaces provided.

(5)

SET word TO 'elephant'

FOR EACH letter FROM word DO

END FOREACH

(Total for Question 4 = 12 marks)



DO NOT WRITE IN THIS AREA

DO NOT WRITE IN THIS AREA

DO NOT WRITE IN THIS AREA

5 Computers can be general-purpose or specific-purpose machines.

(a) The central processing unit (CPU) is responsible for executing a program.

Figure 4 shows some of the hardware components of a computer system.

Complete the table by matching the component to the letters shown in **Figure 4**.

(5)

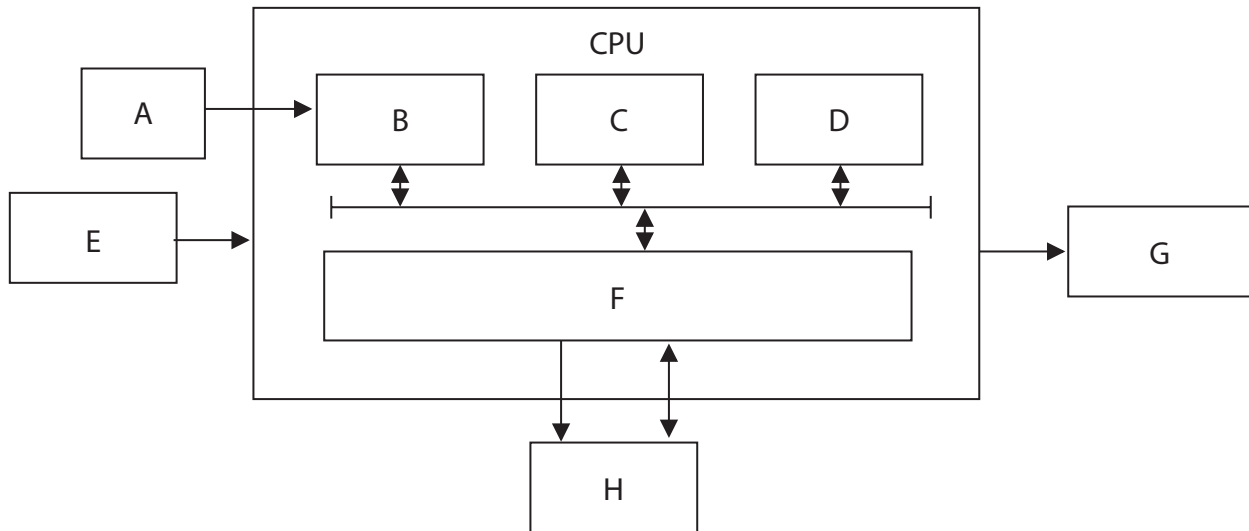

Figure 4

Component	Letter
Control unit	
Output device	
Registers	C
Main memory	
Cache	F
Input device	
Arithmetic/logic unit (ALU)	
Clock	A



(b) The CPU runs a fetch-decode-execute cycle.

- (i) Some registers within the CPU are general-purpose whilst others perform a specific function.

One register is the program counter. Its function is to keep track of the next instruction to be fetched.

Describe how it does this.

(2)

.....

.....

.....

.....

- (ii) The control bus carries signals from the processor to other components.

Identify the signal that would be used during the **fetch** stage of the cycle.

(1)

- A** Memory delete signal
- B** Memory read signal
- C** Memory store signal
- D** Memory write signal

- (iii) Clock speed is the number of pulses the CPU's clock generates per second.

State how increasing the speed of the clock impacts on the fetch-decode-execute cycle.

(1)

.....

.....

(c) An embedded system forms part of a larger system, device or machine.

- (i) Give **two** features of an embedded system.

(2)

1

.....

2

.....



- (ii) There are many factors to consider when choosing a CPU for an embedded system.

For example, the clock speed of the CPU in a TV remote control can be low because it only has to be fast enough to create a low frequency output signal for the TV.

Explain **one other** factor that should be considered when choosing a CPU for an embedded system within a TV remote control.

(2)

.....

.....

.....

.....

(Total for Question 5 = 13 marks)

DO NOT WRITE IN THIS AREA

DO NOT WRITE IN THIS AREA

DO NOT WRITE IN THIS AREA



P 6 9 2 9 7 A 0 1 7 2 0

6 Akiko develops software programs.

(a) Akiko can use a low-level or a high-level programming language to write code.

(i) Give **one** benefit of using a low-level programming language to develop a program.

(1)

(ii) Give **one** drawback of using a low-level programming language to develop a program.

(1)

(b) Akiko is writing an anti-virus program.

(i) The program will include a virus removal function.

Give **two other** functions that should be included.

(2)

1

2

(ii) An anti-virus program is one type of anti-malware.

Give **one other** type of anti-malware.

(1)

DO NOT WRITE IN THIS AREA

DO NOT WRITE IN THIS AREA

DO NOT WRITE IN THIS AREA



(c) Akiko is also working on a burglar alarm system.

The alarm must only be triggered if:

- the alarm (A) is set
- it is dark outside (O)
- a window (W) or a door (D) has been opened.

Construct a Boolean expression, using AND, OR and NOT with the letters A, O, W, and D to show the conditions that will trigger the alarm.

(4)

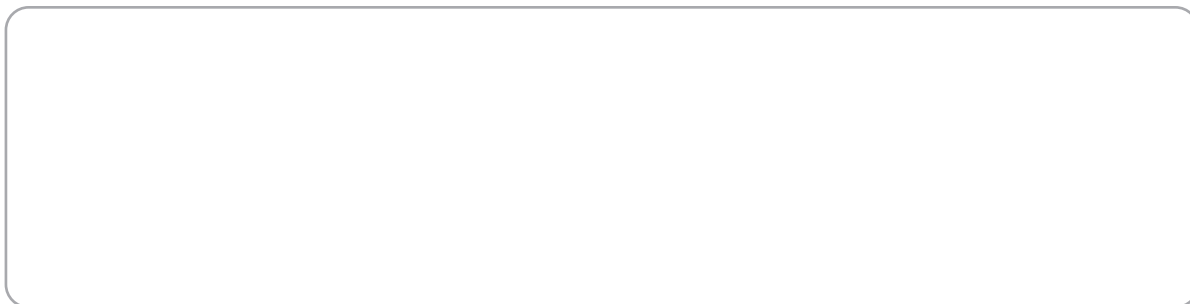

DO NOT WRITE IN THIS AREA

DO NOT WRITE IN THIS AREA

DO NOT WRITE IN THIS AREA



P 6 9 2 9 7 A 0 1 9 2 0

(d) Akiko wants to know how the software she writes can be protected.

Discuss how the software can be protected from illegal copying and/or illegal distribution.

You should consider:

- intellectual property
- licensing.

(6)

DO NOT WRITE IN THIS AREA

DO NOT WRITE IN THIS AREA

DO NOT WRITE IN THIS AREA

(Total for Question 6 = 15 marks)

TOTAL FOR PAPER = 80 MARKS

